



# INDUSTRIAL GRADE PIVi SERIES INVERTERS

## PIVi Microprocessor Control Circuit

- Provides comprehensive yet user friendly interface between the inverter and the operator.
- Control programs can be field upgraded.
- RS232 Communication Port option available.

## PIVi Power Circuit

- A combination of Ferroresonant Output and Pulse Width Control using Bipolar Transistors as Chopper. Field demonstrated MTBF exceeds 250,000 Hours.
- Integral Static Bypass Switch, field selected for 'Online' or 'Offline' operation.

## PIVi Inverter Specifications

### DC Input

Nominal	Range		Output VA
24 V	21 to 29	Vdc	1.2 to 5.0 KVA
48 V	42 to 58	Vdc	1.2 to 10 KVA
120V	105 to 145	Vdc	1.2 to 10 KVA
240V	210 to 290	Vdc	1.2 to 10 KVA

### AC Output

**Voltage (Standard):** 120 Vac 60 Hz Single Phase, 2 wires L & N. For other output voltages, frequency and configurations see options.

**Power Factor:** 0.75 Lagging to Unity

**Line Regulation:**  $\pm 1\%$  at half Load

**Load Regulation:**  $\pm 2\%$  from no load to full load at nominal input voltage.

**Regulation Envelope:**  $\pm 5\%$  maximum for any combination of line voltage, load current and temperature variations within specification.

**Frequency Stability:**  $\pm 0.05\%$  crystal controlled.

**Peak Voltage Deviation:** Within 10% of the steady state peak voltage, for a 50% change of the rated load. Recovers within 100 mSec.

**Harmonic Distortion:** 5% THD, 3% any Single, at nominal input voltage, full load ( linear ) and unity power factor.

**Efficiency:** 79 to 88%

### Output Power VA

Nominal DC Input I <sub>in</sub> = Current at Full load	Output Power VA						
	1,200 VA	1,500 VA	2,000 VA	3,000 VA	5,000 VA	7,500 VA	10,000 VA
24 V I <sub>in</sub> @ 21V	PIVi 1.2K-24 68 amp	PIVi 1.5K-24 85 amp	PIVi 2.0K-24 113 amp	PIVi 3.0K-24 * 169 amp	Replaced by HPi Inverter		
48 V I <sub>in</sub> @ 42V	PIVi 1.2K-48 34 amp	PIVi 1.5K-48 42 amp	PIVi 2.0K-48 56 amp	PIVi 3.0K-48 84 amp	Replaced by HPi Inverter	Discontinued	Replaced by HPi Inverter
120 V I <sub>in</sub> @ 105V	PIVi 1.2K-120 14 amp	PIVi 1.5K-120 17 amp	PIVi 2.0K-120 23 amp	PIVi 3.0K-120 34 amp	PIVi 5.0K-120 56 amp	Discontinued	Replaced by HPi Inverter
240 V I <sub>in</sub> @ 210V	PIVi 1.2K-240 7 amp	PIVi 1.5K-240 9 amp	PIVi 2.0K-240 12 amp	PIVi 3.0K-240 17 amp	PIVi 5.0K-240 28 amp	Discontinued	Replaced by HPi Inverter
<b>Case size</b>	B	B	B	B	C		
<b>Approx Wt.</b>	150 Lbs	170 Lbs	205 Lbs	225 Lbs	400 Lbs		

CSA Certified



### AC Line Input

**Voltage:** 120 Vac  $\pm 10\%$ , 60 Hz  $\pm 1.5$  Hz, 1 $\Phi$  L & N

### Static Bypass Switch

**Transfer Time:** 4 mSec maximum

**Overload Capacity:** 120% for 10 minutes  
1000% for 8 mSec

### Protective features

**DC Input:** Circuit breaker, electronic low and high DC cut off, automatic restart, input capacitor pre-charge switch is provided for 7.5KVA and above units.

**AC Output:** Overload protected by circuit breaker, severe overload or short circuit by electronic shut-down with automatic reset.

**AC input:** Overload protected by circuit breaker, AC line is disconnected by a contactor if abnormal voltage and / or frequency is encountered.

### Environmental

**Cooling:** Natural Convection or assisted by temperature controlled fans.

**Operating Temperature:** -10° to +40° C at full load,  
to +50° C with 25% derating.

**Storage Temperature:** -20° to +75° C

**Operating Humidity:** 0 to 90% at 25° C with no condensation.

\* Indicates Models with Fan assisted cooling

# Inverter Control Panel

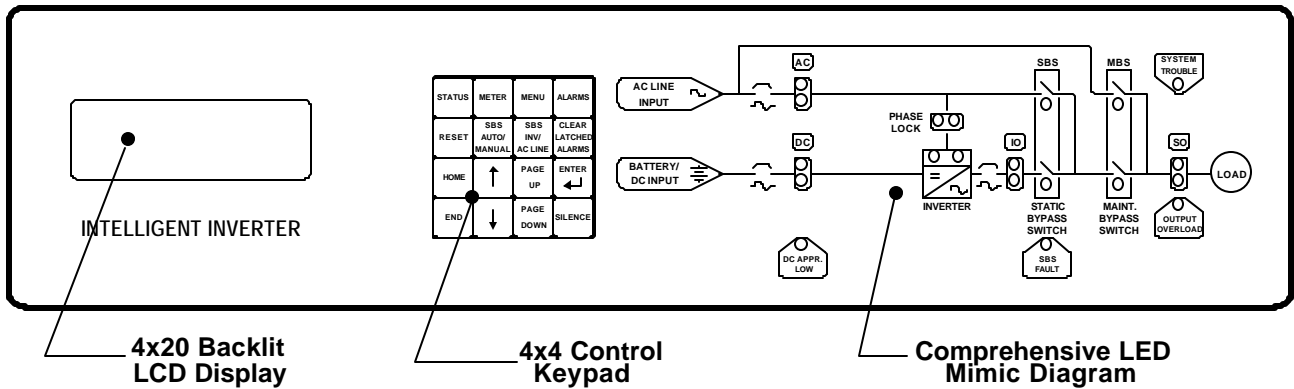

## LCD Display

### 1) Operational Status

- a) Modes of Operation, on-line or off-line.
- b) The source supplying the load, Inverter or AC line.
- c) Static Bypass Switch operation, automatic or manual.
- d) System Output, load percentage and voltage.

### 2) Metering (Standard)

- a) System Output, voltage and current.

#### Metering with EMD Option

- a) System Output, voltage, current and frequency.
- b) Inverter Output, voltage and frequency.
- c) AC Line Input, voltage and frequency.
- d) DC Input, voltage and current.

### 3) Temperature

- a) Ambient in ° C.
- b) Power Module in ° C, fan cooled units only.

### 4) Alarm Listing (29 alarm conditions), displays

- a) Sustained alarms.
- b) Latched alarms, cleared by a keystroke.

## Control Keypad

4 x 4 Touch-pad with tone response.

## Mimic Diagram

The input, output and operational status of functional blocks are indicated by green and red LEDs.

## Standard System Alarms

c/w Dry form C contact

- 1) System Trouble (common) alarm
- 2) DC Approaching Low alarm

Both indicated by:

- a) Blinking LED.
- b) Audible Buzzer, silenced by a keystroke, re-triggered by a subsequent alarm.

## Modes of Operation (Selected by the user, may be changed at any time during operation)

- 1) **On-line:** Inverter preferred. Load is normally supplied by the inverter, but is transferred to the AC line in the event of an overload or inverter fault. After the fault is corrected, the load will be transferred back to the Inverter.
- 2) **Off-line:** AC line preferred. Load is normally supplied by the AC line, but is transferred to the inverter when AC fails. After the AC is restored, the load will be transferred back to the AC line.
- 3) **AC Line not available:** Load is always supplied by the inverter. Alarms associated with AC line fault are inhibited.

Specifications subject to change without notice

Ordering Information, for example:

**PIVi 10K - 48 - C - EMD - MBS...**

Model #      Output Voltage      Options

Output Voltage Table

Code	Output Volt & Freq	Configuration
<b>N</b>	Standard, 120 Vac 60 Hz	2 wires, L - N
<b>A</b>	Option, 220/230 Vac 50 Hz	2 wires, L - N
<b>B</b>	Option, 120/240 Vac 60 Hz	3 wires, L - N - L
<b>C</b>	Option, 240 Vac 60 Hz	2 wires, L - L only
<b>D</b>	Option, 208 Vac 60 Hz	2 wires, L - L only

Option Table

Code	Option
<b>EMD</b>	Enhanced Metering Display, see 'Metering' above
<b>MBS</b>	Internal Maintenance Bypass Switch, make before break, allows most common service with no break
<b>MBSX</b>	External Maintenance Bypass Switch, make before break, allows complete service with no break
<b>RS232</b>	RS232 Communication Port, allows remote control and diagnosis

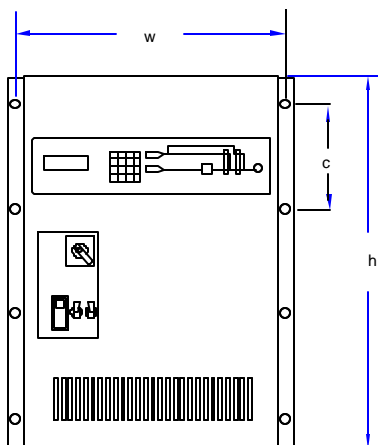
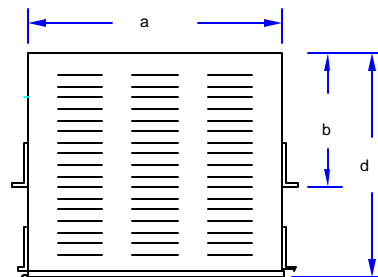

Dimensions in inches

Case	B	C
<b>a</b>	17.00	21.00
<b>b</b>	9.00	9.75
<b>c</b>	7.00	8.50
<b>d</b>	14.75	16.00
<b>h</b>	24.75	36.25
<b>w</b>	19 or 23	23

For more information, please contact

**USA**  
**Philtek Power Corp.**  
 4320 Sweet Rd  
 Blaine WA 98230  
 1-800-727-4877  
 Tel: 360-332-7252  
 Fax: 360-332-7253

**CANADA**  
**Philtek Electronics Ltd**  
 2471 Vauxhall Place  
 Richmond BC V6V 1Z5  
 Tel: 604-270-4642  
 Fax: 604-270-8343